

The Schleibinger Freeze-Thaw Slabtester

The slab-test or Borås test is a frost thaw test for concrete. It is defined in the prEN 12390-9 "Freeze-thaw resistance - Scaling", DIN-EN-1338, DIN-EN 1339, DIN-EN 1340, EN 1367-1 and DIN V 18004. The standards are different in minor details. Please check them if you are in doubt.

Preparing the specimen

The test requires four specimens obtained from four cubes. After 21 days a 50mm thick specimen is sawed from each cube perpendicular to the top surface so that the saw cut for the test surface is located in the center of the cube. So specimens are 15x15x5 cm sized. When the concrete is 25 days old a rubber sheet is glued to all surfaces except the test surface. Place a string of glue around the test surface in the corner between the concrete and the rubber. After 28 days pour a layer about 3 mm deep of de-mineralized water on the top surface for 72h. After 31 days all surfaces except the test surface are thermally insulated with 20mm thick polystyrene foam plastic. Then the de-min. water is replaced by the freezing medium and the test surface is covered with a polyethylene sheet.

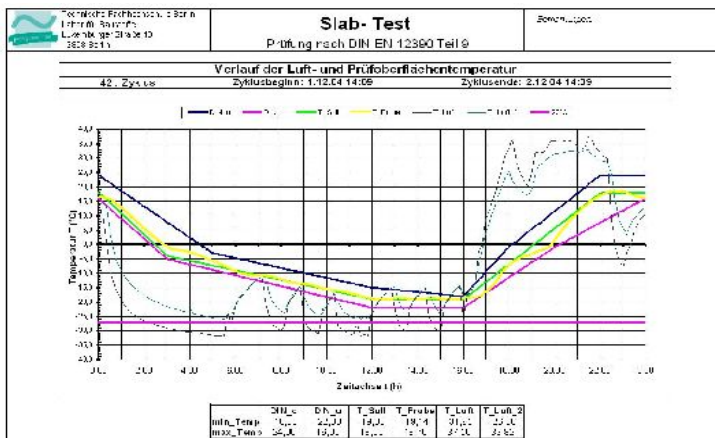

© Figure Technische Fachhochschule Berlin, Labor für Baustoffe
Created by Kristian Siebert for his diploma-thesis WS/SS 04/05
"Vergleichende Untersuchungen zum Frost-Tausalz-Widerstand von Betonen mit dem Slab-Test und CDF-Verfahren - Comparing research about the frost thaw resistance between the Slab test and the CDF test". Chair of : Prof. Dipl.-Ing Jürgen Berger

Temperature Cycles

One frost thaw cycle is run in 24 hours. The temperature shall exceed 0°C during each cycle for at least 7h but not more than 9h.

The reference temperature is measured in the middle of the test surface and may deviate, between ± 5 K and ± 5 K from the target temperature

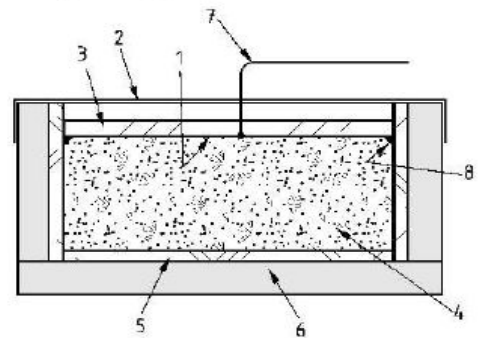

Measuring Scaling

After 7, 14, 28, 42 and 56 days the weight of the scaled material is measured, after the surface has been brushed.

The Slab-Tester

The Schleibinger Slab-Tester is a temperature and time controlled frost-thaw system. It allows freezing and thawing of the concrete specimen according to prEN 12390-9 and prEN 1339 EN 1367-1, DIN V 18004 and 1340:2002. Made of stainless steel. Including: 4 shelves, electronic controller, manual.

Additional Feature: Programming Tool, Internet Interface and Data Logger

This feature makes the Schleibinger Slabtester much more sophisticated. You can input up to 8 programs for the temperature over time. Two add. temperature measuring devices for measuring the temperature in the freezing medium on the test surface and in the air. The data from the last temperature cycles are recorded and can be downloaded from any PC by a Ethernet TCP/IP interface. So the Slabtester can be operated by an Internet browser from any PC in your intranet. Up to 8 own temperature programs may be created. A data acquisition module stores the temperature data of the last 4 weeks. The temperature curve of the last 24h may be plotted on the color touch screen.

Including: TCP/IP interface, add. temperature sensor, color touch screen, software, CF-card, CF-card-reader, user-manual.

Flooding Option

Inside the chamber a stainless steel vessel (ca. 60x50x40cm) is mounted (removable). A 2nd vessel is standing outside. In this outside vessel a pump and a heating unit is mounted. During freezing the inner vessel is empty. For thawing, water from the outside vessel, with an own heating unit, is pumped into the inner vessel. Time for flooding and emptying is free programmable. This option requires the feature "Programming Tool C1041".



This feature for the Slabtester is for testing natural stones according to EN 12371, aggregates according to EN 1367-1 and tile-glue according to EN 1348:2006.

Accessories

Schleibinger is also delivering the accessories required for the test, like funnels, funnel holder, paper filters, Ultra sonic tester for the e-modulus loss etc.

Technical Data

Power supply	V/Hz	110/230V/1Ph/50/60Hz
Power	kW	0.8
Size outside	cm (wxdxh)	70x83x215
Size inside	cm (wxdxh)	51x65x146
Weight (cross/net)	kg	ca. 169 / 147
Temperature range	°C	-30..+40
Maximum specimen weight per shelf	kg	60

Order Codes

Slab Test Equipment	C0103
Intranet Access Programming Tool and Data Logger	C1041
Freeze Thaw Test for Natural Stones / Flooding Option	C0108
Hopper Container	C0017
Hopper	C0018
Filter	C0019
Wooden Packaging	CVP01

04.04.10 /home/markus/www/slabtester/slabtester_US.odt